



**TRUE FOOD SERVICE EQUIPMENT, INC.**

2001 East Terra Lane • P.O. Box 970 • O'Fallon, Missouri 63366  
 (636)240-2400 • Fax (636)272-2408 • (800)325-6152 • Intl Fax# (001)636-272-7546  
 Parts Dept. (800)424-TRUE • Parts Dept. Fax# (636)272-9471 • www.truemfg.com

Project Name: \_\_\_\_\_

Location: \_\_\_\_\_

Item #: \_\_\_\_\_ Qty: \_\_\_\_\_

Model #: \_\_\_\_\_

A/A #

SIS #

Model:  
**GEM-69FC**

**Glass Door Merchandisers:**  
*Glass End Slide Door Floral Case Refrigerator*



**GEM-69FC**

- ▶ Glass end models offer greater product visibility for more attractive floral displays.
  - ▶ Oversized and balanced refrigeration system, factory sealed and pre-lubricated for long life. Designed to hold 35°F (1.6°C) to accommodate a broad range of floral arrangements.
  - ▶ Exterior - non-peel or chip black laminated vinyl; durable and permanent.
  - ▶ Interior - attractive black aluminum interior liner with 300 series stainless steel floor.
  - ▶ Self closing doors. Counter-balanced weight system for smooth, even, positive closing.
  - ▶ "Low-E", double pane thermal glass side panels and door assemblies. The latest in energy efficient technology.
  - ▶ Special interior agro lighting designed for flowers to prevent premature discoloration.
  - ▶ Illuminated exterior sign panel.
  - ▶ Entire cabinet structure is foamed-in-place using high density, CFC free, polyurethane insulation.
- Bottom mounted units feature**
- ▶ "No stoop" lower shelf to maximize product visibility
  - ▶ Storage on top of cabinet.
  - ▶ Easily accessible condenser coil for cleaning.

**ROUGH-IN DATA**

Specifications subject to change without notice.  
 Chart dimensions rounded up to the nearest 1/8" (millimeters rounded up to next whole number).

Model	Doors	Capacity (Cu. Ft.) (liters)	Shelves	Cabinet Dimensions (inches) (mm)			HP	Voltage	Amps	NEMA Config.	Cord Length (total ft.) (total m)	Crated Weight (lbs.) (kg)
				L	D <sup>†</sup>	H						
GEM-69FC	3	69 1954	6	78 <sup>1</sup> / <sub>4</sub>	29 <sup>5</sup> / <sub>8</sub>	79 <sup>1</sup> / <sub>4</sub>	1/2	115/60/1	12.0	5-15P	9	704
				1988	753	2013	1/2	115/60/1	6.5	▲	2.74	320

<sup>†</sup> Depth does not include 3/8" (10 mm) for door handle.

▲ Plug type varies by country.

7/07 Printed in U.S.A.

**APPROVALS:**

**AVAILABLE AT:**

Model:  
**GEM-69FC**

**Glass Door Merchandiser:**  
*Glass End Slide Door Floral Case Refrigerator*



## STANDARD FEATURES

### DESIGN

- True's commitment to using the highest quality materials and refrigeration systems provides the user with dependable product temperatures, and lower utility costs in an attractive merchandiser that brilliantly displays high profit floral arrangements.
- True's floral merchandisers offer interior agro lighting combined with a baffled airflow design which creates the ideal environment to prolong fresh flower shelf life.
- Brilliant black exterior and interior with product accentuating black shelves further entice customers to purchase high profit floral arrangements.

### REFRIGERATION SYSTEM

- Factory engineered, self-contained, capillary tube system using environmentally friendly (CFC free) 134A refrigerant.
- Oversized and balanced refrigeration system, factory sealed and pre-lubricated for long life. Designed to hold 35°F (1.6°C) to accommodate a broad range of floral arrangements.
- Sealed, cast iron, self-lubricating evaporator fan motor(s) and larger fan blades give True merchandisers a more efficient low velocity, high volume airflow design. This unique design ensures faster temperature pull down, dependable holding temperatures and faster recovery in high use situations.
- Baffled airflow provides even air distribution for longer shelf life of fresh flowers.
- Bottom mounted condensing unit positioned for easy maintenance; "no stoop" lower shelf maximizes visibility by raising merchandised product to higher level.

### CABINET CONSTRUCTION

- Exterior - non-peel or chip black laminated vinyl; durable and permanent.
- Glass ends - Low-E, double pane thermal glass assemblies. The latest in energy efficient technology.
- Interior - attractive black aluminum liner with 300 series stainless steel floor.
- Insulation - entire cabinet structure is foamed-in-place using high density, CFC free, polyurethane insulation.
- Welded, heavy duty galvanized frame rail dipped in rust inhibiting enamel paint for corrosion protection inside and out.
- Frame rail fitted with leg levelers.
- Illuminated exterior sign panel.

### DOORS

- "Low-E", double pane thermal glass door assemblies with mitered plastic channel frames. The latest in energy efficient technology.
- Each door fitted with 12" (305 mm) long black PVC handle.
- Self closing doors. Counter-balanced weight system for smooth, even, positive closing.

### SHELVING

- Six (6) adjustable, heavy duty, black PVC coated wire shelves 24<sup>1</sup>/<sub>8</sub>" L x 20<sup>3</sup>/<sub>4</sub>" D (613 mm x 528 mm). Four (4) chrome plated shelf clips included per shelf.
- Shelf support pilasters made of same material as cabinet interior; shelves are adjustable on 1/2" (13 mm) increments.

### LIGHTING

- Safety shielded fluorescent interior lighting.
- Special interior agro lighting designed for flowers to prevent premature discoloration.

- Cabinet lighting utilizes electronic ballast and T-8 bulbs for brighter illumination, longer bulb life and increased energy efficiency.

### MODEL FEATURES

- Evaporator is epoxy coated to eliminate the potential of corrosion.

### ELECTRICAL

- Unit completely pre-wired at factory and ready for final connection to a 115/60/1 phase, 15 amp dedicated outlet. Cord and plug set included.



115/60/1  
NEMA-5-15R

### OPTIONAL FEATURES/ACCESSORIES

Upcharge and lead times may apply.

- 230-240V / 50 Hz.
- White exterior.
- Rosewood exterior.
- Mirrored back.
- 6" (153 mm) standard legs.
- 6" (153 mm) seismic/flanged legs.
- 2<sup>1</sup>/<sub>2</sub>" (64 mm) diameter castors.
- Ratchet locks.
- Additional shelves.
- Remote cabinets (condensing unit supplied by others; system comes standard with 404A expansion valve and requires R404A refrigerant). Consult factory technical service department for BTU information.

## PLAN VIEW

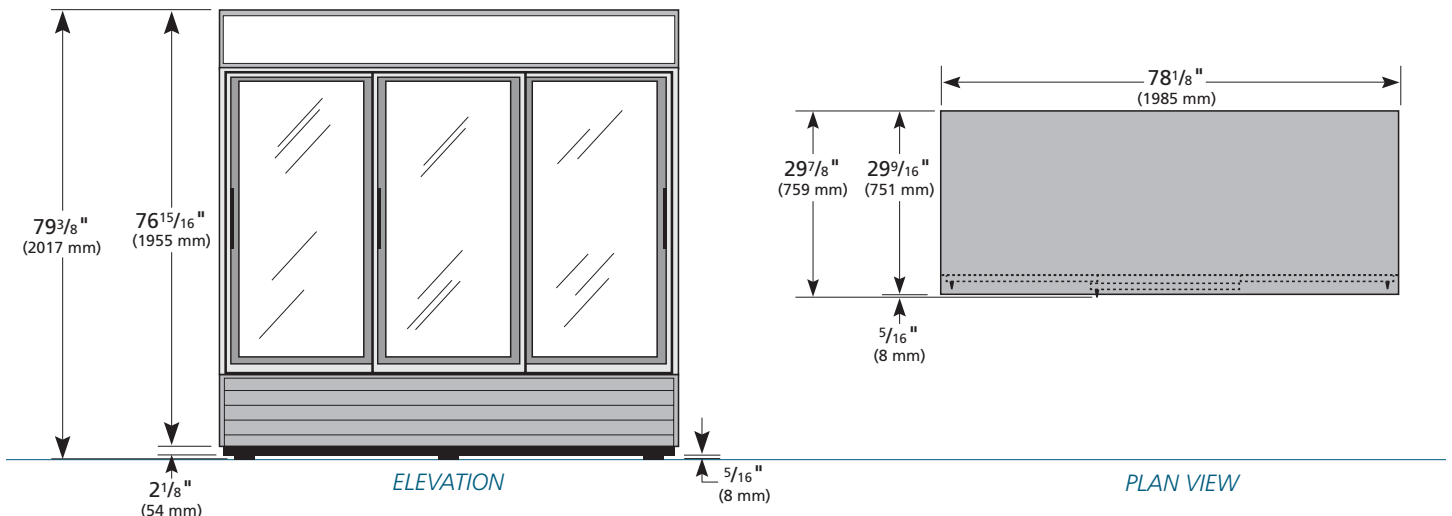

### WARRANTY

One year warranty on all parts and labor and an additional 4 year warranty on compressor. (U.S.A. only)

METRIC DIMENSIONS ROUNDED UP TO THE NEAREST WHOLE MILLIMETER  
SPECIFICATIONS SUBJECT TO CHANGE WITHOUT NOTICE



Model	Elevation	Right	Plan	3D
GEM-69FC	TFBY01E	TFBY01S	TFBY01P	TFBY013

## TRUE FOOD SERVICE EQUIPMENT

2001 East Terra Lane • P.O. Box 970 • O'Fallon, Missouri 63366 • (636)240-2400 • Fax (636)272-2408 • (800)325-6152 • Intl. Fax# (001)636-272-7546 • www.truefmfg.com